

STRESS ANALYSIS

Tower Tech model TTXL-04 & TTXR-04

12' legs

FOR

TOWER TECH, Inc.

BY

J.R. KING ENGINEERING

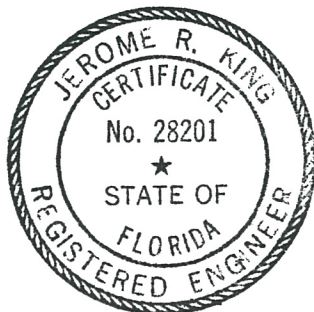

I HEREBY CERTIFY THAT THESE CALCULATIONS
WAS PREPARED BY ME AND THAT I AM
A DULY LICENSED PROFESSIONAL ENGINEER
UNDER THE LAWS OF THE STATE OF
Florida.

SIGNED: *Jerome R. King*

DATE: *12/01/16*

REG. NO. 28201

J.R. KING ENGINEERING

10890 NORTHMARK DRIVE
EDEN PRAIRIE, MN 55344
952.944-1391
JRKINGENG@COMCAST.NET

Title:

Fiberglass modular cooling tower – TTXL-04 & TTXR-04
12' legs

Purpose:

Analyze and design the components of the fiberglass cooling tower.

References:

1. AISC, Steel Construction Manual, 8th edition
2. Structural Engineering Handbook, 2ND edition
By Gaylord & Gaylord, 1973 McGraw-Hill
3. Aluminum Structures, 2nd edition
By J. Randolph Kissell & Robert Ferry
4. Risa3d – Rapid interactive structural analysis,
three dimensional, computer software

Specifications:

1. Tower Tech tests and material properties data
2. Creative Pultrusions, Inc. material properties data

Design Requirements:

The design loads shall be in accordance with the IBC (International Building Code). Wind, seismic and gravity loadings are applied. The illustrated tower shell and substructure is designed to withstand a wind pressure of 91.6 psf. (ASCE7-10 200 mph wind, exposure C) and a seismic force factors: SDC E, $S_s = 3$, $S_1 = 2$, soil class D.

Procedures:

Procedures are the methodologies indicated in the listed references, as specifically presented within the calculations. To use the AISC equations and built-in sections within risa3d, the fiberglass properties have been put in place of the steel; the printouts that have "Steel" headings are calculated as fiberglass and should be interpreted as such. The properties of the fill material are based on actual in-house tests. Safety factors are calculated and compared to those for steel, aluminum, and wood.

Conclusions:

The analysis and design of the subject cooling tower and their appurtenances have been completed satisfactorily.

DATE:	23 Jun 2016
DRAWING#:	
PROJECT#:	
DWG TYPE:	SPECIAL
DRAWN BY:	BM
CHECKED BY:	
	6

CONSTRUCTION
LIBRARY
DRAWING

Bracing Scheme for Seismic
and Wind Load Applications
TTXL-04 & TTXR-04
Model #

TOWER TECH, Inc.
THE TECHNOLOGY COMPANY
Oklahoma City, Oklahoma



Modular
Cooling Tower

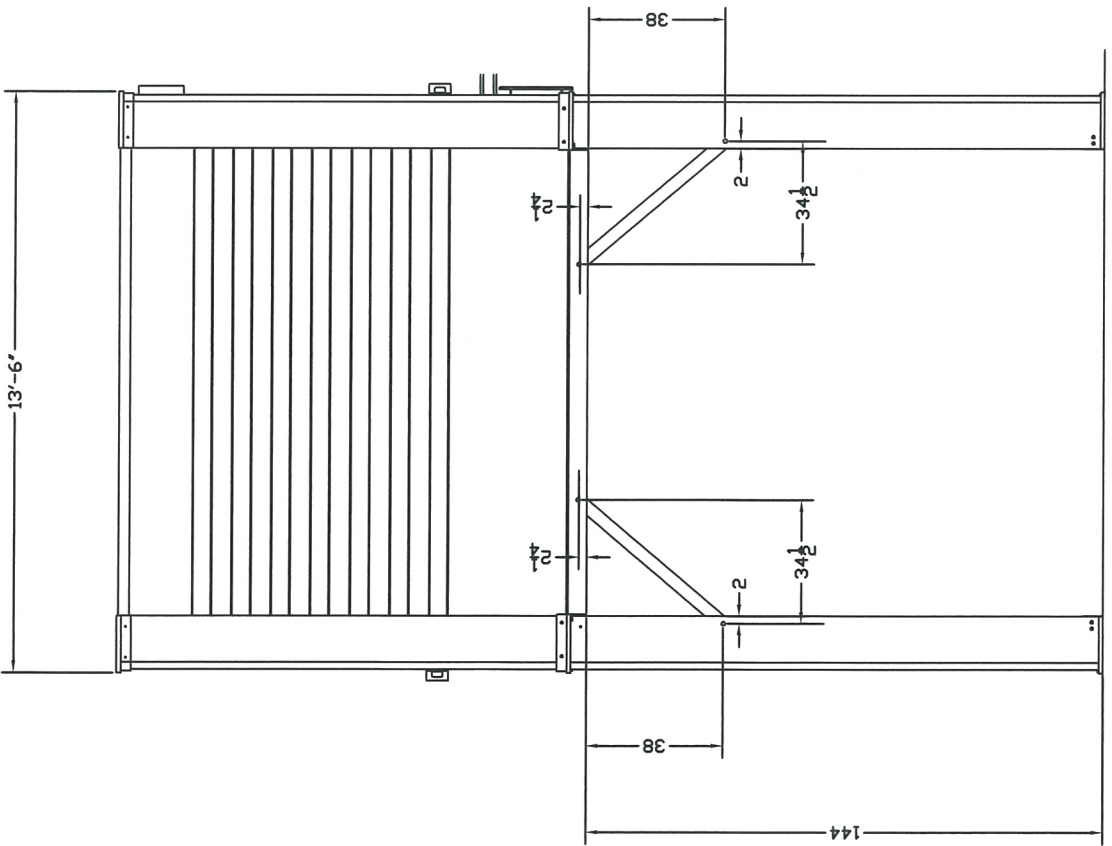
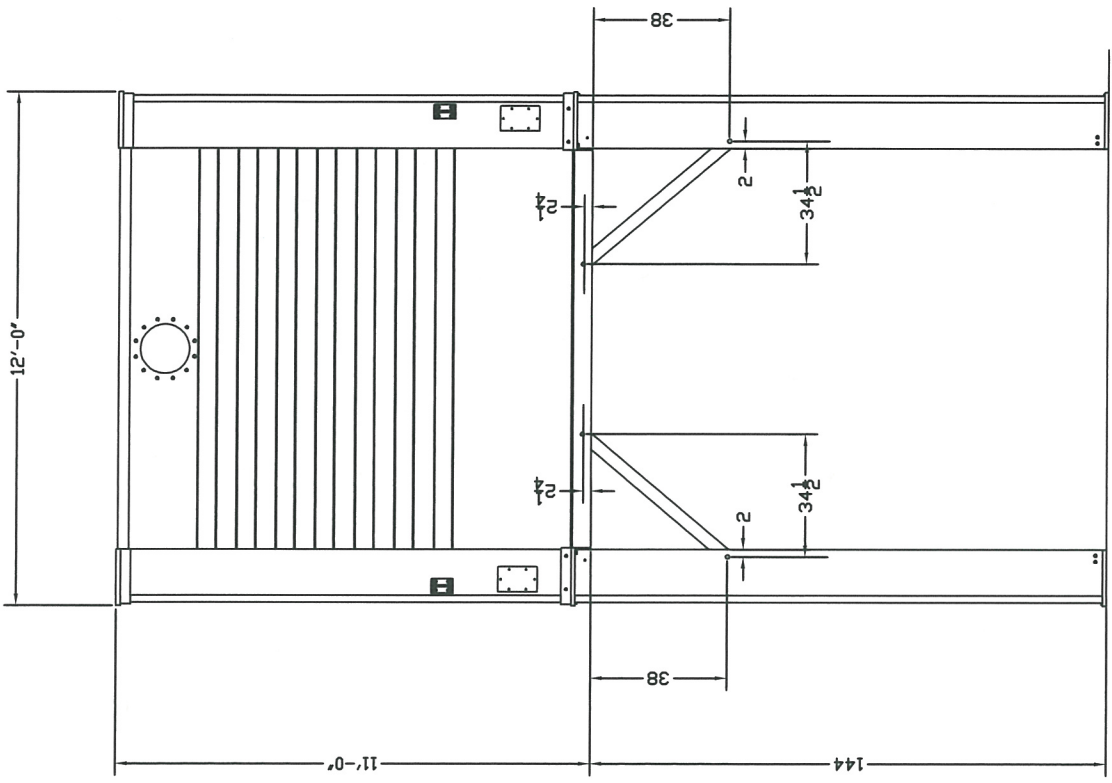

STANDARD BRACING UP TO 144 INCH SUBSTRUCTURE

LATERAL FORCES

Lateral Wind

200 mph, exposure "C" RISK III OR IV

$$qz = .00256(200)^2 \times 2 \times 9 \times 9 = 82.9$$

$$F_x = 82.9 \times 85.1 \times 1.3 \times A_f = 91.6 A_f$$

Seismic Forces

Largest spectral response accelerations

$$S_s = 300\%g, S_1 = 200\%g \quad \text{Soil class "D", } F_a = 1.0, F_v = 1.5$$

$$S_{ms} = 1 \times 3.0 = 3.0 \quad S_{ds} = 2/3 \times S_{ms} = 2.0$$

$$S_{m1} = 1.5 \times 2 = 3.0 \quad S_{d1} = 2/3 \times S_{m1} = 2.0$$

Importance Factor = 1.0

Seismic Design Category = E

Select $R = 3.0$ $\Omega = 2$ $C_d = 2.5$ (table 15.4-1)

Elevated tanks, vessels, on symmetrically braced legs (sec 15.7.10)

ASCE/SEI 7-10 (Chapter 15)

Section 15.4 go to Section 12.8

Seismic base shear: $V = C_s \times W$

Operational weight, $W = 13,758$ lbs

$$C_s = S_{ds} / (R/I) = 2/3$$

$$V = C_s \times W = 9,172 \text{ lbs}$$

Chapter 16, FBC Building Structural Design

SECTION 1609 WIND LOADS

FIGURE 1609A ULTIMATE DESIGN WIND SPEEDS, V_{alt} FOR RISK CATEGORY II BUILDINGS AND OTHER STRUCTURES

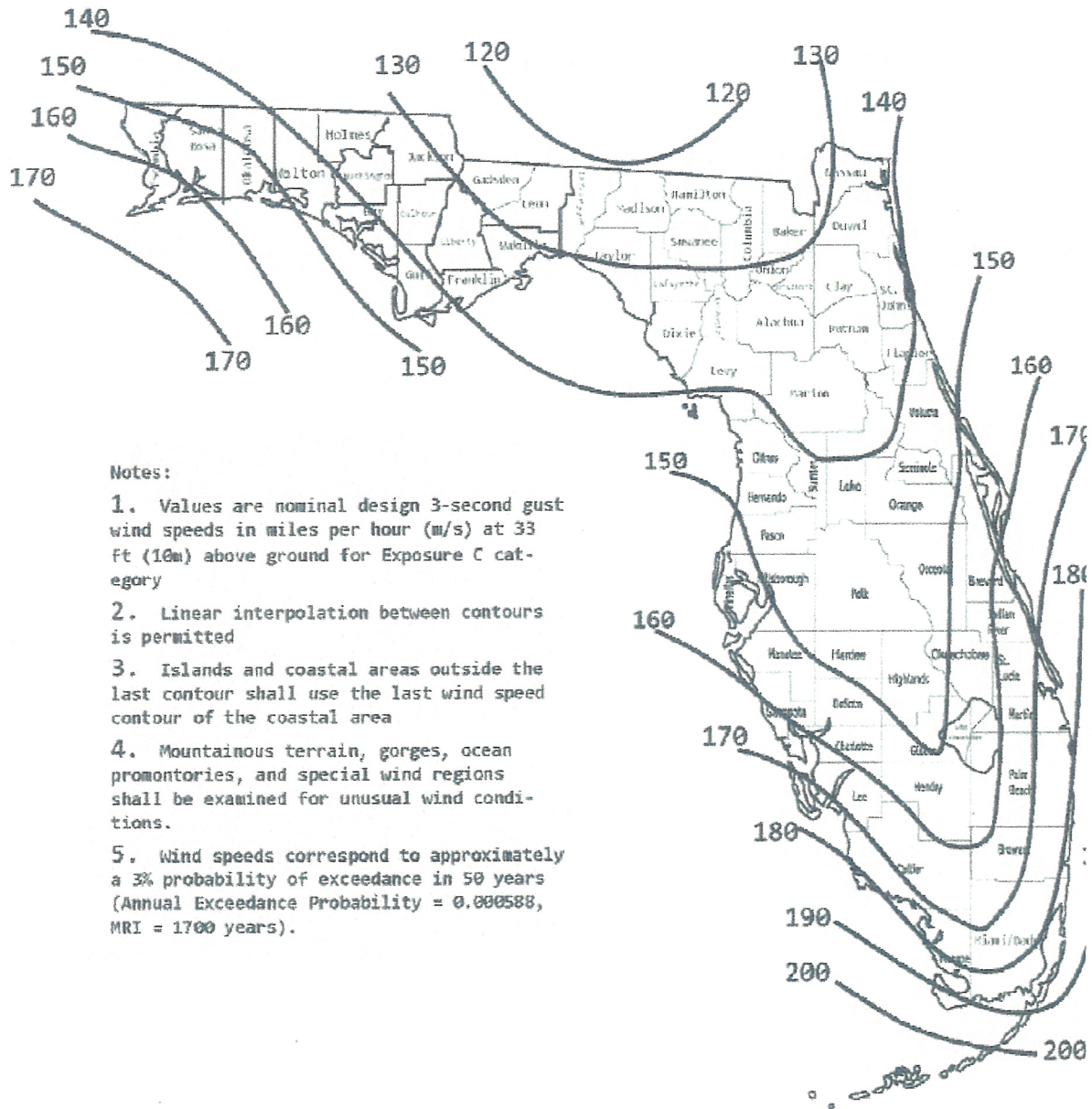
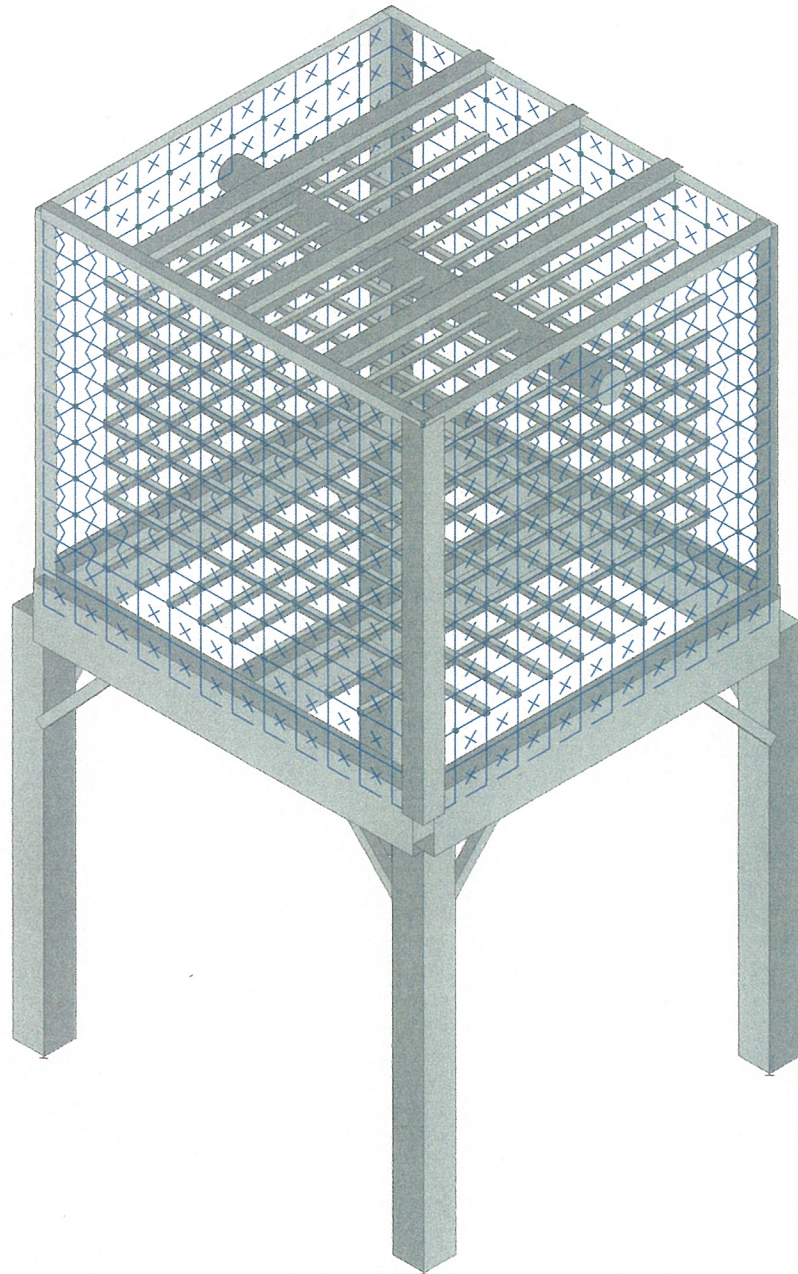

FIGURE 1609B ULTIMATE DESIGN WIND SPEEDS, V_{alt} FOR RISK CATEGORY III AND IV BUILDINGS AND OTHER STRUCTURES



Envelope Only Solution

J.R. King Engineering

Jerry King

Tower Tech TTXL

SK - 1

Dec 8, 2016 at 1:21 PM

TTXL-04.r3d



Company : J.R. King Engineering
 Designer : Jerry King
 Job Number :
 Model Name : Tower Tech TTXL

Dec 8, 2016
 1:24 PM
 Checked By: _____

Hot Rolled Steel Properties

	Label	E [ksi]	G [ksi]	Nu	Therm (11... Density[k/ft^3]	Yield[ksi]	Ry	Fu[ksi]	Rt	
1	fiberglass	2000	500	.12	.44	.11	20	1.2	58	1.1

General Material Properties

	Label	E [ksi]	G [ksi]	Nu	Therm (1E5 F)	Density[k/ft^3]
1	FIBERGLASSPL	2000	500	.12	.44	.11
2	RIGID	1e+5		0	0	0
3	GM3	25	6	.12	.44	0

Hot Rolled Steel Section Sets

	Label	Shape	Type	Design List	Material	Design Ru...	A [in2]	Iyy [in4]	Izz [in4]	J [in4]
1	C-1	HSS12x12x6	Column	Single Angle	fiberglass	Typical	16	357	357	561
2	C-2	L8x8x14	Column	Single Angle	fiberglass	Typical	13.3	79.7	79.7	3.46
3	B-1	HSS20x8x10	Beam	Tube	fiberglass	Typical	30.3	338	1440	916
4	B-2	HSS20x8x10	Beam	Tube	fiberglass	Typical	30.3	338	1440	916
5	B-3	HSS20x8x10	Beam	Tube	fiberglass	Typical	30.3	338	1440	916
6	B-4	L4x4x8	Beam	Single Angle	fiberglass	Typical	3.75	5.52	5.52	.322
7	B-5	L4x4x8	Beam	Single Angle	fiberglass	Typical	3.75	5.52	5.52	.322
8	B-6	W6x20	Beam	Wide Flange	fiberglass	Typical	5.87	13.3	41.4	.24
9	PIPE	PIPE 10.0	Beam	Pipe	fiberglass	Typical	11.5	151	151	302
10	BR-1	HSS3.5x3.5x4	VBrace	Tube	fiberglass	Typical	2.91	5.04	5.04	8.35
11	COLLECTOR	C8x11.5	Beam	Channel	fiberglass	Typical	3.37	1.31	32.5	.13

General Section Sets

	Label	Shape	Type	Material	A [in2]	Iyy [in4]	Izz [in4]	J [in4]
1	GEN1	RE4X4	Beam	FIBERGLASSPL	16	21.333	21.333	31.573
2	RIGID		None	RIGID	1e+6	1e+8	1e+8	1e+6
3	FILL	RE2X2	Beam	GM3	4	1.333	1.333	1.973

Load Combinations

	Description	Sol..	PDelta	SRSS	BLC	Fa...	BLC	Factor	BLC	Fac...	BLC	Fa...	BLC	Fa...	BLC	Fa...	BLC	Fa...	BLC	Fa...
1	SEISMIC				SX*...	1	SZ*SF	1												
2	IBC 16-8	Yes			DL	1														
3	IBC 16-9	Yes			DL	1	LL	1												
4	IBC 16-12 (a) ..	Yes			DL	1	WLX	.6												
5	IBC 16-12 (a) ..	Yes			DL	1	WLZ	.6												
6	IBC 16-13 (a) ..	Yes			DL	1	WLX	.45	LL	.75										
7	IBC 16-13 (a) ..	Yes			DL	1	WLZ	.45	LL	.75										
8	IBC 16-15 (a) Yes				DL	.6	WLX	.6												
9	IBC 16-15 (b) Yes				DL	.6	WLZ	.6												
10	IBC 16-12 (b) ..	Yes			DL	1	Sds*DL	.14	SX*SF	.7	SZ*...	.21								
11	IBC 16-12 (b) ..	Yes			DL	1	Sds*DL	.14	SZ*SF	.7	SX*...	.21								
12	IBC 16-12 (b) ..	Yes			DL	1	Sds*DL	.14	SX*SF	.7	SZ*...	-.21								
13	IBC 16-12 (b) ..	Yes			DL	1	Sds*DL	.14	SZ*SF	.7	SX*...	-.21								
14	IBC 16-14 (a) ..	Yes			DL	1	Sds*DL	.105	SX*SF	.525	SZ*...	.158	LL	.75						
15	IBC 16-14 (a) ..	Yes			DL	1	Sds*DL	.105	SZ*SF	.525	SX*...	.158	LL	.75						
16	IBC 16-14 (a) ..	Yes			DL	1	Sds*DL	.105	SX*SF	.525	SZ*...	-.1...	LL	.75						
17	IBC 16-14 (a) ..	Yes			DL	1	Sds*DL	.105	SZ*SF	.525	SX*...	-.1...	LL	.75						
18	IBC 16-16 (a) Yes				DL	.6	Sds*DL	-.14	SX*SF	.7	SZ*...	.21								
19	IBC 16-16 (b) Yes				DL	.6	Sds*DL	-.14	SZ*SF	.7	SX*...	.21								
20	IBC 16-16 (c) Yes				DL	.6	Sds*DL	-.14	SX*SF	.7	SZ*...	-.21								



Company : J.R. King Engineering
 Designer : Jerry King
 Job Number :
 Model Name : Tower Tech TTXL

Dec 8, 2016
 1:24 PM
 Checked By: _____

Load Combinations (Continued)

Description	Sol..	PDelta	SRSS	BLC Fa...	BLC	Factor	BLC	Fac...	BLC Fa...	BLC Fa...	BLCFa.....	BLCFact..	BLC Fact...
21	IBC 16-16 (d)	Yes		DL	.6	Sds*DL	-.14	SZ*SF	.7	SX*..	-.21		

Basic Load Cases

BLC	Description	Category	X Gravity	Y Gravity	Z Gravity	Joint	Point	Distribu..	Area(Me..	Surface..
1	DEAD	DL		-1						
2	FILL	DL						2		
3	WATER	LL						2		
4	WIND-Z	WLZ								121
5	WIND-X	WLX								121
6	DEFLECTION	None								

Envelope Joint Reactions

Joint	X [k]	LC	Y [k]	LC	Z [k]	LC	MX [k-ft]	LC	MY [k-ft]	LC	MZ [k-ft]	LC
1	N3	max	1.688	5	7.607	13	.462	20	0	2	0	2
2		min	-1.652	18	-3.96	20	-1.626	11	0	2	0	2
3	N2	max	1.647	9	7.476	12	.48	12	0	2	0	2
4		min	-1.694	10	-4.099	21	-1.605	19	0	2	0	2
5	N1	max	1.688	5	7.099	7	.517	12	0	2	0	2
6		min	-1.655	20	-4.099	19	-1.605	21	0	2	0	2
7	N4	max	1.647	9	7.607	11	.492	20	0	2	0	2
8		min	-1.691	12	-3.527	9	-1.626	13	0	2	0	2
9	Totals:	max	6.65	9	15.659	16	1.925	20				
10		min	-6.65	4	2.808	19	-6.416	11				

Envelope AISC ASD Steel Code Checks

Member	Shape	Code Check	Loc[ft]	LC	Shear ...	Loc.....	LCFa [ksi]	Ft [ksi]	Fb y-y [ksi]	Fb z-z...	Cb	Cmy	Cmz	ASD ...	
1	M32	HSS3.5x3....	.516	2.121	5	.011	0	y 11 6.146	12	13.2	13.2	1	.6	1	H1-1
2	M29	HSS3.5x3....	.516	2.121	5	.011	4.4...	y 13 6.146	12	13.2	13.2	1	.6	1	H1-1
3	M31A	HSS3.5x3....	.515	2.121	10	.011	0	y 13 6.146	12	13.2	13.2	1	.6	1	H1-1
4	M30A	HSS3.5x3....	.515	2.121	4	.011	4.4...	y 11 6.146	12	13.2	13.2	1	.6	1	H1-1
5	M31	HSS3.5x3....	.495	2.121	11	.011	0	y 12 6.146	12	13.2	13.2	1	.6	1	H1-1
6	M29A	HSS3.5x3....	.495	2.121	13	.011	4.4...	y 10 6.146	12	13.2	13.2	1	.6	1	H1-1
7	M3	HSS12x12x6	.326	8.694	12	.068	8.8...	y 10 8.118	12	13.2	13.2	1	.6	.6	H1-2
8	M2	HSS12x12x6	.326	8.694	10	.068	8.8...	z 12 8.118	12	13.2	13.2	1	.6	.6	H1-2
9	M1	HSS12x12x6	.322	8.694	13	.068	8.8...	y 5 8.118	12	13.2	13.2	1	.6	.6	H1-2
10	M4	HSS12x12x6	.305	8.816	12	.068	8.8...	z 5 8.118	12	13.2	13.2	1	.6	.6	H1-2
11	M30	HSS3.5x3....	.249	2.302	19	.011	0	y 12 6.146	12	13.2	13.2	1	.6	1	H2-1
12	M32A	HSS3.5x3....	.249	2.302	21	.011	4.4...	y 10 6.146	12	13.2	13.2	1	.6	1	H2-1
13	M6	L8x8x14	.151	0	14	.057	10....	z 4 1.457	12	- Code check b...					H1-1
14	M5	L8x8x14	.151	0	16	.058	10....	y 4 1.457	12	- Code check b...					H1-1
15	M7	L8x8x14	.144	0	17	.081	10....	y 5 1.457	12	- Code check b...					H1-1
16	M18	L4x4x8	.111	5.051	5	.193	1.01	y 4 .356	12	- Code check b...					H1-1
17	M8	L8x8x14	.099	0	7	.082	10....	z 5 1.457	12	- Code check b...					H1-1
18	M23	W6x20	.072	5.612	4	.002	0	y 11 1.339	12	15	12	1	.99	.85	H1-1
19	M10	HSS20x8x10	.052	9.061	5	.014	0	z 19 5.522	12	13.2	13.2	1	.463	.85	H1-1
20	M9	HSS20x8x10	.052	9.061	5	.014	11....	y 11 5.522	12	13.2	13.2	1	.458	.85	H1-1
21	M11	HSS20x8x10	.051	8.082	13	.013	2.9...	y 11 6.321	12	13.2	13.2	1	.208	.85	H1-2
22	M12	HSS20x8x10	.051	8.082	11	.013	2.9...	y 13 6.321	12	13.2	13.2	1	.208	.85	H1-2
23	M17	L4x4x8	.038	8.082	21	.114	9.99	z 5 .356	12	- Code check b...					H1-1
24	M19	W6x20	.026	5.388	5	.002	0	y 13 1.339	12	15	12	1	.957	.85	H1-1
25	M20	W6x20	.015	5.5	5	.002	0	y 11 1.339	12	15	12	1	.99	.85	H1-1
26	M15	L4x4x8	.010	8.082	7	.021	10....	y 4 8.037	12	- Code check b...					H1-1



Envelope AISC ASD Steel Code Checks (Continued)

Member	Shape	Code Check	Loc[ft]	LC	Shear ...	Loc.....	LC Fa [ksi]	Ft [ksi]	Fb y-y [ksi]	Fb z-...Cb	Cmy	cmz	ASD ...
27	M16	L4x4x8	.010	8.082	7	.021	10.... z	4 8.037	12	- Code check b...			H1-1
28	M24	PIPE_10.0	.009	6	11	.002	0	13 6.274	12	13.2	13.2	1 .6	.85 H1-2
29	M13	HSS20x8x10	.003	5.388	5	.001	0	y 11 6.321	12	13.2	13.2	1 .884	.85 H2-1

Envelope Joint Displacements

Joint	X [in]	LC	Y [in]	LC	Z [in]	LC	X Rotation [rad]	LC	Y Rotatio...	LC	Z Rotatio...	LC		
1	N1267	max	5.46	8	-.004	19	2.06	19	2.409e-04	19	1.604e-03	4	3.117e-04	9
2		min	-5.46	5	-.031	16	-6.18	12	-7.835e-05	12	-1.604e-03	9	-3.117e-04	4
3	N1268	max	5.458	4	-.005	20	2.06	19	2.473e-04	11	1.655e-03	5	3.116e-04	5
4		min	-5.458	9	-.032	15	-6.18	12	-7.144e-05	20	-1.655e-03	8	-3.116e-04	8
5	N1269	max	5.384	4	-.004	20	2.06	19	2.576e-04	11	4.185e-03	5	3.05e-04	5
6		min	-5.384	9	-.034	15	-6.18	12	-6.871e-05	20	-4.185e-03	8	-3.05e-04	8
7	N1266	max	5.384	8	-.001	19	2.06	19	2.38e-04	19	4.266e-03	4	3.053e-04	9
8		min	-5.384	5	-.032	16	-6.18	12	-8.884e-05	12	-4.266e-03	9	-3.053e-04	4
9	N1270	max	5.248	4	-.003	20	2.06	19	2.671e-04	11	9.411e-03	5	2.91e-04	5
10		min	-5.248	9	-.037	15	-6.18	12	-6.593e-05	20	-9.411e-03	8	-2.91e-04	8
11	N1265	max	5.248	8	.002	19	2.06	19	2.347e-04	19	9.357e-03	4	2.917e-04	9
12		min	-5.248	5	-.033	16	-6.18	12	-9.89e-05	12	-9.357e-03	9	-2.917e-04	4

Envelope Plate/Shell Principal Stresses

Plate	Surf...	Sigma1 [ksi]	LC	Sigma2 [ksi]	LC	Tau Max [ksi]	LC	Angle [rad]	LC	Von Mises [ksi]	LC	
1	P636	max T	3.248	8	.037	8	1.607	4	1.595	8	3.231	4
2		min	-.056	5	-3.249	5	.006	2	.025	9	.012	2
3		max B	3.257	5	.043	9	1.61	5	1.596	9	3.239	5
4		min	-.061	4	-3.257	8	.006	2	.019	20	.012	2
5	P526	max T	3.234	8	.094	8	1.572	4	1.933	3	3.19	4
6		min	-.112	5	-3.236	5	.006	2	-.026	7	.012	2
7		max B	3.244	5	.099	9	1.575	5	1.933	3	3.198	5
8		min	-.118	4	-3.244	8	.006	2	-.131	16	.012	2
9	P572	max T	3.607	9	1.48	9	1.065	4	1.775	19	3.145	4
10		min	-1.483	4	-3.612	4	.003	3	-.161	21	.004	3
11		max B	3.604	4	1.461	4	1.071	4	1.767	21	3.14	4
12		min	-1.461	9	-3.595	9	.003	3	-.177	19	.004	3
13	P441	max T	3.498	8	1.031	8	1.235	5	1.585	7	3.117	5
14		min	-1.032	5	-3.502	5	.002	2	-.005	20	.003	2
15		max B	3.47	9	.973	9	1.25	4	1.586	6	3.104	4
16		min	-.974	4	-3.475	4	.002	2	.015	7	.003	2
17	P583	max T	3.484	9	1.375	9	1.056	4	2.245	3	3.044	4
18		min	-1.378	4	-3.489	4	.003	3	-.611	2	.005	3
19		max B	3.481	4	1.355	4	1.063	4	2.245	3	3.04	4
20		min	-1.355	9	-3.473	9	.003	3	-.611	2	.005	3

Properties

	ASTM TEST METHOD	UNITS/VALUE	SERIES 500/525 SHAPES	SERIES 625 SHAPES	SERIES 500/525 PLATE ⑤			SERIES 625 PLATE ⑤		
					1/8" 3.175mm	3/16" - 1/4" 4.76-6.35mm	3/8" - 1" 9.5-25.4mm	1/8" 3.175mm	3/16" - 1/4" 4.76-6.35mm	3/8" - 1" 9.5-25.4mm
MECHANICAL										
Tensile Stress, LW	D638	psi N/mm ²	30,000 207	30,000 207	20,000 138	20,000 138	20,000 138	20,000 138	20,000 138	20,000 138
Tensile Stress, CW	D638	psi N/mm ²	7,000 48.3	7,000 48.3	7,500 51.7	10,000 68.9	10,000 68.9	7,500 51.7	10,000 68.9	10,000 68.9
Tensile Modulus, LW	D638	10 ⁶ psi 10 ⁹ N/mm ²	2.5 17.2	2.6 17.9	1.8 12.4	1.8 12.4	1.8 12.4	1.8 12.4	1.8 12.4	1.8 12.4
Tensile Modulus, CW	D638	10 ⁶ psi 10 ⁹ N/mm ²	0.8 5.52	0.8 5.52	0.7 4.83	0.9 6.21	1.4 9.65	1.0 6.89	1.0 6.89	1.4 9.65
Compressive Stress, LW	D695	psi N/mm ²	30,000 207	30,000 207	24,000 165	24,000 165	24,000 165	24,000 165	24,000 165	24,000 165
Compressive Stress, CW	D695	psi N/mm ²	15,000 103	16,000 110	15,500 107	16,500 114	20,000 138	16,500 114	17,500 121	17,500 121
Compressive Modulus, LW	D695	10 ⁶ psi 10 ⁹ N/mm ²	2.5 17.2	2.6 17.9	1.8 12.4	1.8 12.4	1.8 12.4	1.8 12.4	1.8 12.4	1.8 12.4
Compressive Modulus CW	D695	10 ⁶ psi 10 ⁹ N/mm ²	0.8 6.89	0.8 6.89	0.7 6.89	0.9 6.89	1.4 6.89	1.0 6.89	1.0 6.89	1.4 6.89
Flexural Stress, LW	D790	psi N/mm ²	30,000 207	30,000 207	35,000 241	35,000 241	30,000 207	35,000 241	35,000 241	30,000 207
Flexural Stress, CW	D790	psi N/mm ²	10,000 68.9	10,000 68.9	13,000 89.6	15,000 103	18,000 124	13,000 89.6	15,000 103	18,000 124
Flexural Modulus, LW	D790	10 ⁶ psi 10 ⁹ N/mm ²	1.6 11.0	1.6 11.0	1.8 12.4	2 13.8	2 13.8	1.8 12.4	2 13.8	2 13.8
Flexural Modulus, CW	D790	10 ⁶ psi 10 ⁹ N/mm ²	0.8 5.52	0.8 5.52	0.9 6.21	1.1 7.58	1.4 9.65	1.0 6.89	1.1 7.58	1.4 9.65
Modulus of Elasticity ①	full section	10 ⁶ psi 10 ⁹ N/mm ²	2.6 17.9	2.8 19.3						
Modulus of Elasticity: W & I shapes > 4" W & I shapes > 102mm	full section	10 ⁶ psi 10 ⁹ N/mm ²	2.5 17.2	2.5 17.2						
Parallel Compressive Shear Stress, LW ② ③	D3846	psi N/mm ²	3,000 20.7	3,000 20.7						
Shear Modulus, LW ③ ④	—	10 ⁶ psi 10 ⁹ N/mm ²	0.425 2.93	0.425 2.93						
Short Beam Shear, LW ⑤ ⑥	D2344	psi N/mm ²	4,500 31.0	4,500 31.0						
Bearing Stress, LW	D953	psi N/mm ²	30,000 207	30,000 207	32,000 220.6	32,000 221	32,000 221	32,000 221	32,000 221	32,000 221
Poisson's Ratio, LW ④	D3039	in/in mm/mm	0.33 .330	0.33 .330	0.31 .310	0.31 .310	0.31 .310	0.32 .320	0.32 .320	0.32 .320
Notched Izod Impact, LW	D256	ft-lbs/in J/mm	25 1.33	25 1.33	15 .801	10 .533	10 .533	15 .801	10 .533	10 .533
Notched Izod Impact, CW	D256	ft-lbs/in J/mm	4 .214	4 .214	5 .267	5 .267	5 .267	5 .267	5 .267	5 .267
PHYSICAL										
Barcol Hardness	D2583	—	45 ④	45 ④	40	40	40	40	40	40
24 hr Water Absorption ⑦	D570	% Max	0.6	0.6	0.6	0.6	0.6	0.6	0.6	0.6
Density	D792	lbs/in ³ 10 ⁻³ g/mm ³	.062-.070 1.72-1.94	.062-.070 1.72-1.94	.060-.068 1.66-1.88	.060-.068 1.66-1.88	.060-.068 1.66-1.88	.060-.068 1.66-1.88	.060-.068 1.66-1.88	.060-.068 1.66-1.88
Coefficient of Thermal Expansion, LW ④	D696	10 ⁻⁶ in/in/°F 10 ⁻⁶ mm/mm/°C	4.4 8.0	4.4 8.0	4.4 8.0	4.4 8.0	4.4 8.0	4.4 8.0	4.4 8.0	4.4 8.0
Thermal Conductivity ④	C177	BTU-in/ft ² Hr/°F w/(m ² *K)	4 .58	4 .58						

All values are minimum ultimate properties from coupon tests except as noted.

- ① This value is determined from full section simple beam bending of EXTREN® structural shapes.
- ② The shear stress test results will change radically if the notched orientation is altered. The value in this chart represents the test configuration where the notches are machined parallel to the reinforcing mat. For notches machined perpendicular to the reinforcing mat, this value would be two to three times larger.
- ③ The Shear Modulus value has been determined from tests with full sections of EXTREN® structural shapes. (See Strongwell's Strongwell Design Manual for further information.)
- ④ Value would be 50 if the surfacing veil were not there.
- ⑤ Plate compressive stress/modulus measured edgewise and flexural stress/modulus measured flatwise.
- ⑥ Values apply to Series 525 and 625.
- ⑦ Measured as a percentage maximum by weight.
- ⑧ Span to depth ratio of 3:1; EXTREN® angles will have a minimum value of 4000 psi and the I/W shapes are tested in the web.
- ⑨ Typical values because these are shape and composite dependent tests.

LW — Lengthwise PF — Perpendicular to laminate face
CW — Crosswise N.T. — Not Tested

Specifications for Wall Sections of Tower Tech, Inc. ("Buyer")

1. **Definition of "Products":** The terms "Products," as used hereinafter, shall mean finished "Perimeter Basin Wall," finished "Center Basin," finished "Mid Wall," and finished "Top Wall," all manufactured by the pultrusion process.
2. **Material Technical Properties:** Products to, at a minimum, conform to the following typical properties of pultruded materials:

Mechanical Properties (Coupon Sample, u.n.o.)	ASTM Test Method	Polyester
Properties at 100% at 77°F (90% at or below 100°F, 80% at 100-125°F, 70% at 125-150°F)		
Specific Gravity	ASTM D792	1.75
Density, lb/in cubed	ASTM D792	0.07
Tensile Strength, LW, psi	ASTM D638	33,000
Tensile Strength, CW, psi	ASTM D638	7,500
Tensile Modulus of Elasticity, LW, ksi	ASTM D638	3,000
Tensile Modulus of Elasticity, CW, ksi	ASTM D638	1,000
Compressive Strength, LW, psi	ASTM D695	33,000
Compressive Strength, CW, psi	ASTM D695	17,000
Comp. Modulus of Elasticity, LW, ksi	ASTM D695	3,000
Comp. Modulus of Elasticity, CW, ksi	ASTM D695	1,000
Flexural Strength, LW, psi	ASTM D790	33,000
Flexural Strength, CW, psi	ASTM D790	10,000
Flexural Modulus, LW, ksi	ASTM D790	2,000
Flexural Modulus, CW, ksi	ASTM D790	1,000
Modulus of Elasticity, ksi	Perimeter Basin & Center Basin, Full Section	3,200
Modulus of Elasticity, ksi	Mid Wall & Top Wall, Full Section	2,200
Shear Modulus, ksi	Full Section	420
Shear Strength by Punch, PF, psi	ASTM D732	6,000
Bearing Stress, LW, psi	ASTM D953	30,000
Bearing Stress, CW, psi	ASTM D953	18,000
Izod Impact, Notched, LW, ft-lb/in	ASTM D256	30
Izod Impact, Notched, CW, ft-lb/in	ASTM D256	5
Barcol Hardness	ASTM D2583	45
Possion's Ratio, LW, in/in	ASTM D3039	0.35
Possion's Ratio, CW, in/in	ASTM D3039	0.1+E105

(LW = Lengthwise; CW = Crosswise; PF = Perpendicular to Laminate Face)

Thermal Properties	ASTM Test Method	Polyester
Coef. Of Linear Expansion in/in/F	ASTM D696	?
Thermal Conductivity, BTU/hr/sq ft/F/in	ASTM D C177	?

Flammability	ASTM Test Method	Polyester
Flammability Classification	UL94	94V-O
Flammability Extinguishing	ASTM D635	Self-extinguish.
NBS Smoke Chamber	ASTM E662	650
Flame Resistance (Ignition/Burn), sec	FTMS 406-2023	55/30

Other Properties	ASTM Test Method	Polyester
Water Absorption, % 24 hr.	ASTM D570	0.5 Max
Customer Standard Color	-----	Specific Beige
NSF Potable Water Approved	-----	-----